

**SIR ARTHUR LEWIS COMMUNITY COLLEGE**  
**DEPARTMENT OF PROFESSIONAL AND LIFELONG LEARNING**

EXAMINATION SESSION : Semester Two 2025  
LECTURER : Lindsley Philbert  
COURSE TITLE : Electrical Installation – Level 1  
COURSE CODE : ELE 215  
DATE : 6 May, 2025  
COMMENCEMENT TIME : 4:00 pm  
DURATION : 2 hours  
INVIGILATOR :

**INSTRUCTIONS:**

- This paper comprises 20 true and false questions and 45 multiple-choice questions. Total 65 Marks
- You must circle the letter corresponding to the correct answer and provide T or F following the responses.
- Attempt all questions

1. Without magnetism, the electrical world we perceive today would not exist
2. The magnets used in their primitive compasses were called lodestones or loadstones.
3. Lodestones were crude pieces of iron ore known as magnetite.
4. The only other natural magnet is the Earth itself.
5. Every magnet has two points opposite each other that most readily attract pieces of aluminum
6. Opposite ends of a magnet are called poles
7. A magnet attracts a bit of iron because of some glue that exists around the magnet
8. Lines of force move from North to South.
9. The entire group of magnetic field lines of the magnet is called the magnetic flux.
10. Magnetic materials are those materials that are attracted or repelled by a magnet and which can be magnetized themselves.
11. of hard magnetic materials, such as cobalt steel, that retain their magnetism when the magnetizing field is removed.
12. A temporary magnet is one that does not retain a magnetized state when the magnetizing field is removed.
13. Permeability refers to the ability of a magnetic material to concentrate magnetic flux.
14. Any material that is easily magnetized has high permeability.
15. Ferromagnetic materials, Paramagnetic materials, and Diamagnetic materials are all attracted to a magnet.
16. Electromagnets use pressure to get them magnetized.
17. An electromagnet can be used to control electrical switches.
18. Inductance in series is added to find the total inductance.
19. Inductance is measured in Hertz.
20. Electromagnetic circuits are inductance circuits.

1. The Bird does not get shocked because

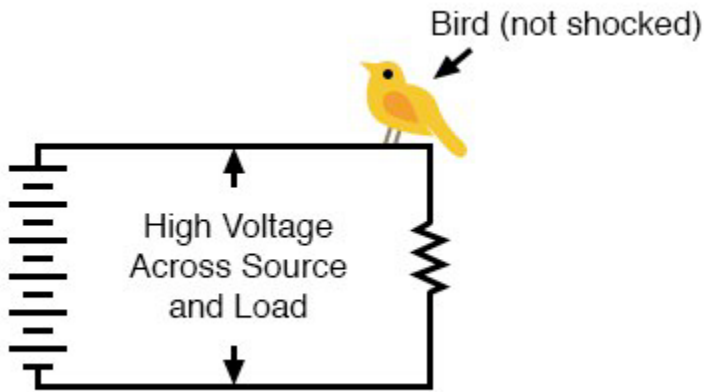

- a) It is insulated from an electric current
- b) Its feet are too close together
- c) There is no current path
- d) It is too high above ground.

2. In a transformer, the energy is conveyed from primary to secondary

- a) Through cooling coil
- b) Through the air
- c) By the flux
- d) None of the above

3. Primary winding of a transformer

- a) Is always a low-voltage winding
- b) Is always high voltage winding
- c) Could either be a low voltage or high voltage winding
- d) None of the above

4. Which winding in a transformer has a greater number of turns

- a) Low voltage winding
- b) High voltage winding
- c) Primary winding
- d) Secondary winding

5. A common method of cooling a power transformer is

- a) Natural air cooling
- b) Air blast cooling
- c) Oil cooling
- d) Water cooling

6. The transformer ratings are usually expressed in terms of

- a) Voltage
- b) Amperes
- c) Kw
- d) KVA

7. Material used for the construction of the transformer core is usually

- a) Wood
- b) Copper

- c) Aluminum
- d) iron

8. A transformer oil must be free from

- a) Sludge
- b) Odour
- c) Gases
- d) moisture

9. The leakage flux in a transformer depends upon

- a) Load current
- b) Load current and voltage
- c) Load current, voltage and frequency
- d) Load current, voltage, frequency and power

10. Silicon steel used in laminations mainly reduces

- a) Hysteresis loss
- b) Eddy current losses
- c) Copper losses
- d) All of the above

11. Power transformers are generally designed to have maximum efficiency around

- a) No- load
- b) Half-loaded
- c) Near full-load
- d) 10% overload

12. During short-circuit test iron losses are negligible because

- a) The current on the secondary side is negligible
- b) The voltage on the secondary side does not vary
- c) The voltage applied on the primary side is low
- d) Full load current is not supplied to the transformer

13. An ideal transformer is one that has

- a) No losses and magnetic leakage
- b) Interleaved primary and secondary windings
- c) A common core for its primary and secondary windings
- d) Core of stainless steel and ending of pure copper metal

14. When a given transformer is run at its rated voltage but reduced frequency, its

- a) Flux density remains unaffected
- b) Iron losses are reduced
- c) Core flux density is reduced
- d) Core flux density is increased

15. In an actual transformer the iron loss remains practically constant from no load to full load because

- a) Secondary voltage remains constant
- b) Primary voltage remains constant
- c) Core flux remains practically constant

d) Value of the transformation ratio remains constant

16. An ideal transformer will have maximum efficiency at a load such that

- a) Copper loss = iron loss
- b) Copper loss < iron loss
- c) Copper loss > iron loss
- d) All of the above

17. The transformer laminations are insulated from each other by

- a) Mica strip
- b) Thin coat of varnish
- c) Paper
- d) Sheet steel

18. The noise produced by a transformer is termed

- a) Zoom
- b) Hum
- c) Ringing
- d) buzz

19. If a transformer is switched on to a voltage more than the rated voltage

- a) Its power factor will deteriorate
- b) Its power factor will increase
- c) Its power factor will remain unaffected
- d) Its power factor will be zero

20. In our domestic houses, the electrical appliances are connected:

- a) In Parallel with the source only if it is a high-power appliance
- b) In series with the source
- c) Some in series and some in parallel with the source
- d) In parallel with the source

21. Lamps in street lighting are all connected in:

- a) Parallel
- b) Series
- c) Series-parallel combination
- d) End to end

22. One of these devices is not used for protection:

- a) RCD
- b) MCB
- c) Fuse
- d) Socket outlet

23. The color of the circuit protective conductor (CPC) is:

- a) Green- Yellow
- b) Green-red

- c) Green-blue
- d) Green-black

24. The earth's potential is taken as:

- a) Negative
- b) Infinite
- c) One Volt
- d) Zero

25. The house wiring, brown and green wires indicate:

- a) Earth and neutral respectively
- b) Phase and neutral respectively
- c) Phase and earth respectively
- d) Neutral and earth respectively

26. The purpose of earthing electric appliances is:

- a) To provide safety against shock
- b) To ensure that appliances work properly
- c) To ensure that the appliances get full voltage
- d) None of the above

27. Electricity is made at a power plant by a huge:

- a) Motor
- b) Generator
- c) Coil
- d) Starter

28. What is earthing?

- a) Connecting electrical machines to earth
- b) Providing a connection to the ground
- c) Connecting the electrical machines to the source
- d) Providing a source of current

29. Who is responsible for ensuring that all workers are using their safety equipment?

- a) Safety officer
- b) Supervisor
- c) Employer
- d) Worker

30. Which of these describes mathematical formulas for OHM'S Law

- a)  $E=IxR$
- b)  $R=V/I$
- c)  $I=V/R$
- d) All of the above

31. Which of the following is a good insulator?

- a) Silver
- b) Water
- c) Copper
- d) Plastic

32. Which of these could be used as a Resistor in a circuit?

- a) Pencil
- b) Gas Engine
- c) Conduit

d) Electric motor

33. Earthing is necessary to give protection against:

- a) Danger of electric shock
- b) Voltage fluctuation
- c) Overloading
- d) High temperature of the conductors

34. The power in a series circuit is the \_\_\_\_\_ of the individual powers

- a) Sum
- b) Minus
- c) Divide
- d) Multiply

35. The formula to calculate current (I) in a series resistance circuit is:

- a)  $I=V/R$
- b)  $I=I^2 \times R$
- c)  $I=V \times R$
- d)  $I=R/V$

36. When current flows through a conductor, electrical energy is converted into \_\_\_\_\_ energy

- a) Chemical
- b) Heat
- c) Light
- d) Sound

37. For current to flow, the circuit should be:

- a) Parallel
- b) In series
- c) Close
- d) open

38. Electricity flows through any:

- a) Material
- b) Insulator
- c) Conductor
- d) State of Matter

39. Ohm's law describes the mathematical relationship between:

- a) Ohm's power, kilohms
- b) Ampere, fuse bulb'
- c) Resistance, voltage, current
- d) Electromotive force, voltage and current

40. The primary function of a fuse is to:

- a) Open the circuit
- b) Protect the appliances
- c) Protect the line
- d) Prevent excessive current from flowing through the circuit

41. There are five resistors in a series circuit, and each resistor has 6V dropped across it. The source voltage is

- a) 6V
- b) 12V
- c) 18V
- d) 30V

42. Three lights are connected in parallel across a 120 volt source. If one light burns out:

- a) The remaining two will glow dimmer
- b) The remaining two will glow brighter
- c) The remaining two will not light
- d) The remaining two will glow with the same brightness as before

43. In an electric line, a fuse is connected to which of the following wires?

- a) Earth
- b) Phase
- c) Neutral
- d) Not connected

44. The third pin in a 3-pin plug is provided so as to:

- a) Provide an earth connection
- b) Provide a 3-phase supply when required
- c) Provide a spare phase when required
- d) Prevent the plug being reversed in the socket

45. Five  $100\Omega$  resistors are connected in parallel. If one resistor is removed, the total resistance is:

- a)  $25\Omega$
- b)  $500\Omega$
- c)  $100\Omega$
- d)  $20\Omega$